

**Control System – I**

P. Pages : 4

Time : Three Hours



**NKT/KS/17/7393**

Max. Marks : 80

- Notes :
1. All questions carry marks as indicated.
  2. Solve Question 1 OR Questions No. 2.
  3. Solve Question 3 OR Questions No. 4.
  4. Solve Question 5 OR Questions No. 6.
  5. Solve Question 7 OR Questions No. 8.
  6. Solve Question 9 OR Questions No. 10.
  7. Solve Question 11 OR Questions No. 12.
  8. Assume suitable data whenever necessary.
  9. Illustrate your answers whenever necessary with the help of neat sketches.
  10. Use of non programmable calculator is permitted.

1. a) Determine the ratio  $\frac{C(s)}{R(s)}$  for the system shown in 'Fig. 1 (a)'. Use Block reduction technique. 7

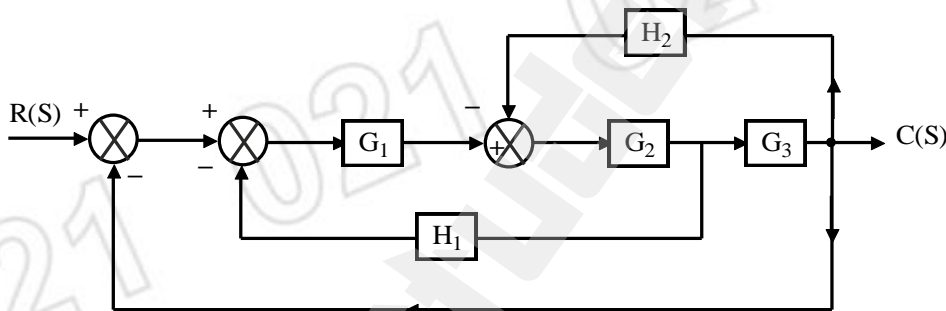

Fig. 1 (a)

- b) Draw the signal flow graph and hence find out the transfer function of the circuit shown in 'Fig. 1 (b)'. 6

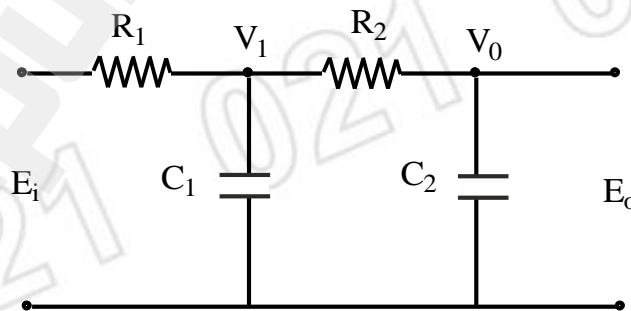

Fig. 1 (b)

OR

2. a) Derive the transfer function  $\frac{X(s)}{F(s)}$  for the mechanical system as shown in 'Fig. 2 (a)'. 7

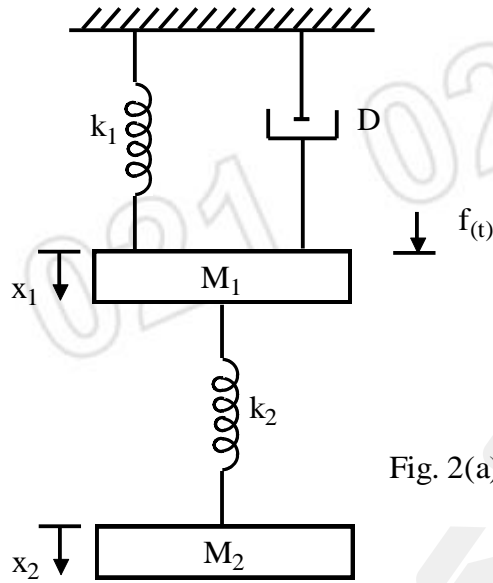

Fig. 2(a)

- b) Define control system in brief with suitable examples. Also differentiate types citing appropriate examples. 6
3. a) The block diagram of a position control system is shown in 'Fig. 3 (a)'. 7

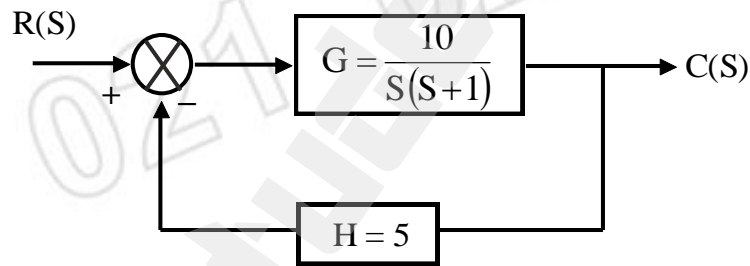

Fig. 3(a)

Determine the sensitivity of closed loop transfer function T with respect to G & H, the forward path & feedback path transfer functions respectively for  $\omega = 100$  rad/sec.

- b) Obtain the transfer function of a field controlled D. C. Servomotor. Draw the block diagram. 6
- OR**
4. a) Define servomechanism. Write a short note on synchro transmitter & receiver pair with a neat sketch. 7
- b) Explain potentiometer as an error detector. 6
5. a) For a system having forward path transfer function  $G(s) = \frac{K}{s(s+6)}$  and  $H(s) = 1$ . Find the time response to an input  $r(t) = 2u(t)$ . where (i)  $k = 13$  (ii)  $k = 8$ . 7

b) A unit step input response data for a second order closed loop system is given below:-

7

t sec	C(t) o/p
0	0
0.05	0.25
0.1	0.8
0.15	1.08
0.2	1.16
0.25	1.02
0.3	0.98
0.35	0.95
0.4	1
0.45	1

i) Plot this data on graph paper and find time response specification  $t_d$ ,  $t_p$ ,  $t_r$ ,  $M_p$  and  $t_s$ .

ii) Obtain O/L and C/L transfer function.

OR

6. a) The block diagram of an electronic pacemaker for controlling the rate of heart beats is shown in 'Fig. 6 (a)'. Assuming unity feedback and  $k = 400$ , Calculate

9

- The output  $c(t)$  for unit step input.
- Steady-state error for unit ramp input.
- Determine  $k$  if the error to a ramp input is 0.02.

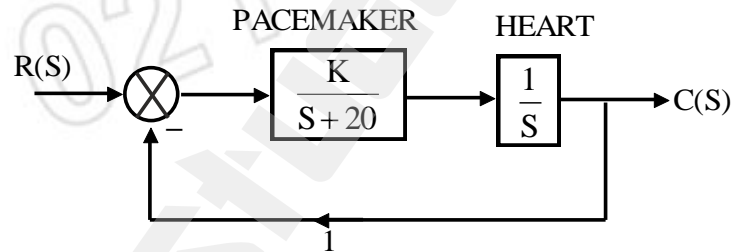

Fig. 6(a)

b) What is meant by PD control? State the effect of PD controller on system performance.

5

7. a) Sketch the root locus for a unity feedback system with open loop transfer function.

9

$$G(s) = \frac{k}{s(s+2)(s^2+2s+2)}$$

b) For the system with characteristic Equation  $s^3 + 5s^2 + 6s + 30 = 0$ . comment on the stability.

4

OR

8. a) Plot the root locus for a unity feedback closed loop system whose open loop transfer

8

function is  $G(s) = \frac{k}{s(s+3+j2)(s+3-j2)}$ .

- b) A unity feedback control system has open loop transfer function given by 5  

$$G(s) = \frac{Ke^{-T_d s}}{s(s^2 + 5s + 9)}$$
. Determine the range of K for stability when  $T_d = 0$ .

9. a) The specification on a second order unity feedback control system with the closed-loop transfer function. 7

$$\frac{C(S)}{R(S)} = \frac{w_n^2}{s^2 + 2S W_n S + w_n^2}$$

are that the overshoot of the step response should not exceed 12 % and the peak time must be less than 0.25. Find the corresponding frequency, response value of peak resonance, resonant frequency and Bandwidth.

- b) Sketch the polar plot for the system with open loop transfer function 6

$$G(s)H(s) = \frac{1}{(s+4)(s+2)}$$

**OR**

10. Construct the bode plots for a unity feedback control system having. From 13

$$G(s) = \frac{2000}{s(s+1)(s+100)}$$
. The Bode plot determine-

- i) Gain crossover frequency.                      ii) Phase crossover frequency.  
 iii) Gain margin.                                      iv) Phase margin.  
 v) Comment on the stability of the system.

11. a) Obtain the state model for the given transfer function. 7

$$G(s) = \frac{Y(s)}{U(s)} = \frac{K[c_2 s + c_1]}{s^3 + a_3 s^2 + a_2 s + a_1}$$

- b) Write the state equation for the circuit shown in 'Fig. 11. (b)'. 7

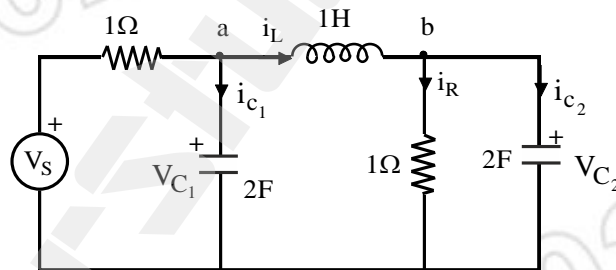

Fig. 11(b)

**OR**

12. a) Given the state model. 8

$$\dot{x} \begin{bmatrix} 1 & 2 \\ 3 & 4 \end{bmatrix} x + \begin{bmatrix} 1 \\ 1 \end{bmatrix} U$$

$$y = \begin{bmatrix} 1 & 0 \\ 0 & 2 \end{bmatrix} x + \begin{bmatrix} 1 \\ 0 \end{bmatrix} U.$$

Determine the transfer function.

- b) Determine the state model of the system characterized by the differential equation. 6

$$(s^4 + 2s^3 + 8s^2 + 4s + 3) y(s) = 10U(s).$$

Use phase variable method.

\*\*\*\*\*